

# WIRE WIZARD<sup>®</sup>

WELDING PRODUCTS

**SUBMERGED ARC & LARGE WIRE WELDING SOLUTIONS**



**FAMILY OWNED  
AMERICAN MADE**

**IF IT TOUCHES THE WIRE, THE WIZARD HAS A SOLUTION!**

# TABLE OF CONTENTS

<b>OPTIMIZED SAW SYSTEM</b> . . . . .	<b>1</b>	<b>CONDUIT</b> . . . . .	<b>5</b>	<b>GUIDE MODULES FOR LARGE WIRE</b> . . . . .	<b>8</b>
<b>POWERBALL® SAW TORCH</b> . . . . .	<b>2</b>	<b>CONNECTORS &amp; ADAPTERS</b> . . . . .	<b>6</b>	<b>LARGE GUIDE MODULE FLEX</b> . . . . .	<b>10</b>
<b>MECHANICAL TURN TABLES</b> . . . . .	<b>3</b>	<b>CONDUIT BALANCERS &amp; HANGERS</b> . . . . .	<b>7</b>	<b>WIRE PILOT FEED ASSISTS</b> . . . . .	<b>11</b>
<b>SAW WIRE DELIVERY SYSTEMS</b> . . . . .	<b>4</b>	<b>WIRE STRAIGHTENERS</b> . . . . .	<b>7</b>	<b>DRUM AND REEL HANDLING EQUIPMENT</b> . . . . .	<b>13</b>

VISIT [WIRE-WIZARD.COM](http://WIRE-WIZARD.COM) TO SEE OUR COMPLETE LINE OF INNOVATIVE WELDING PRODUCTS

## SAW MANIPULATOR WIRE DELIVERY SYSTEM EXAMPLE

The setup shown here represents an optimized wire delivery system configuration for submerged arc welding with a large manipulator. Wire Pilot® Feed Assists, Guide Modules and low friction conduit for large wire are implemented to minimize the pull force on the wire feeder for smooth wire delivery and superior welding performance.

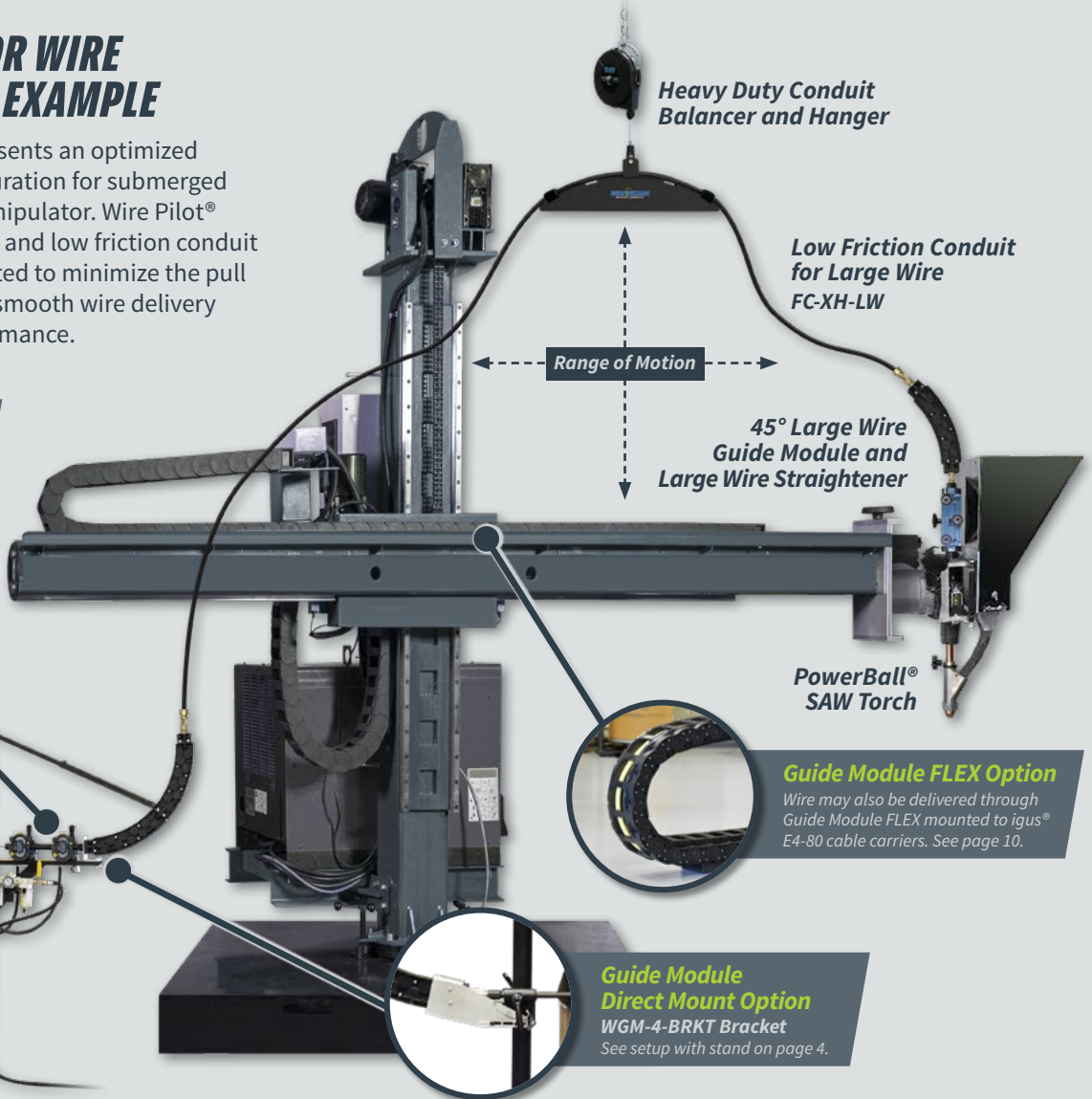

**Dual Drive Feed Assist Option**  
May take place of two Feed Assists in some applications. See page 11.

Heavy Duty Conduit Balancer and Hanger

Low Friction Conduit for Large Wire FC-XH-LW

Range of Motion

45° Large Wire Guide Module and Large Wire Straightener

PowerBall® SAW Torch

**Guide Module FLEX Option**  
Wire may also be delivered through Guide Module FLEX mounted to igus® E4-80 cable carriers. See page 10.

**Guide Module Direct Mount Option**  
WGM-4-BRKT Bracket  
See setup with stand on page 4.

**Mechanical Turn Table**  
with tandem Wire Pilot® Feed Assists and 90° Large Guide Module Assembly

### COMPONENTS IN THIS CONFIGURATION

Part No.	Description	Qty
WWTT-2012	Mechanical Turn Table for up to 5/32" (4 mm) Wire	1
WWTT-COVER-13	Cover for Mechanical Turn Table	1
PFA-WWTT-B2	Feed Assist Kit for Turn Table w/2 Feed Assists (+ drive rolls)	1
WWTT-WGM-SA	Support Arm for Large Wire Guide Modules	1
WGM-LW-1	Large Wire Guide Modules (45° sections)	3
WGM-ECK-LW-50	End Cap Kits for Large Wire Guide Modules	2
WGM-LW-049	Large Guide Module Male Fitting (attached at WSL-100)	1
FC-XH-LW	Extra Flexible Conduit for Large Wire (length will vary)	50'
A-5HD	Quick Disconnect for FC-XH-LW Large Wire Conduit	2

Part No.	Description	Qty
A-4HD	Quick Disconnect for Large Wire (attached at WSL-100)	1
A-9 / A-6HD	Male Compression fitting for FC-XH-LW Conduit	2
RCH-22-27-SH	Conduit Balancer with Shock Stop — Load: 22 – 27 lbs	1
CHH-22	22" (559 mm) Conduit Hanger	1
WSL-100	Large Wire Straightener	1
A-1LN-LW	Inlet Guide for Wire Straightener	1
WS-10S	Inlet Adapter for Lincoln Electric® SAW Wire Feeder	1
WTP-SAW-1-6K	PowerBall® SAW Torch Kit, 6" (152 mm) Length	1

# THE WIRE WIZARD® OPTIMIZED SAW SYSTEM

When it comes to welding wire, submerged arc (SAW) wire is the “king of beasts” and can be extremely difficult to feed. Wire Wizard® provides a full line of wire delivery equipment for SAW welding for monster wire sizes up to 7/32" (5.5 mm), including Mechanical Turn Tables, Guide Modules® for large wire, large wire conduit, Wire Pilot® Feed Assists and the high performance PowerBall® SAW Torch utilizing our patented long-lasting, high conductivity consumable design.

The image below displays our SAW solutions offered for a typical Submerged Arc welding setup. Tame the beast with Wire Wizard® SAW products!



## CONDUIT HANGERS & BALANCERS PAGE 7

Conduit and cable support for applications with manipulators or gantries.



## LARGE WIRE CONDUIT PAGE 5

Engineered to withstand the demands of large wire feeding.



## WIRE GUIDE MODULE SYSTEM PAGE 8

Innovative design eliminates skid friction around bends and turns in the wire delivery system.



## LARGE WIRE STRAIGHTENERS PAGE 7

Lightweight, yet robust wire straighteners for straightening or recasting large wire.



## POWERBALL® SAW TORCH PAGE 2

High performance PowerBall® design for maximum conductivity and extended tip life.



## MECHANICAL TURN TABLE PAGE 3

Essential component for dispensing large wire in drums. Vertical dereelers also available.



## WIRE PILOT® FEED ASSIST PAGE 11

Provides simple and effective “push-pull” system to eliminate wire skid friction in MIG and SAW welding.

# POWERBALL® SAW TORCH

The new **PowerBall® SAW Torch** redefines performance and durability for SAW welding torches. Utilizing the patent pending PowerBall® contact tip design with an all copper current path, the torch features **50% LESS electrical resistance** than traditional SAW torch designs, resulting in energy efficient operation with longer lasting consumables. In a recent application, **PowerBall® SAW contact tips lasted 5X longer than the previous tips** used by the manufacturer! Combine the power of the PowerBall® SAW Torch with Wire Wizard® SAW wire delivery equipment for the ultimate submerged arc welding system.

- ▶ All-copper current path provides maximum conductivity with superior efficiency
- ▶ Long lasting SAW contact tips last up to 5X longer or more
- ▶ Butress threads provide high axial force and better electrical contact
- ▶ Rounded tip design provides smooth flux distribution and improved arc stability
- ▶ SAW torch assemblies available for common lengths (14" shown in photo)
- ▶ Proudly Made in USA



Length specified in kit part numbers (14" as shown). Measured from back of the power lug to the tip.

**Complete 14" SAW Torch Assembly**  
WTP-SAW-1-14K  
Complete assemblies for other lengths available, contact tips sold separately



## UP TO 5X OR MORE\* CONTACT TIP LIFE!



Contact tips are available for most common SAW wire sizes.

\*Results taken in SAW application using 5/32" wire. Previous sub arc tip lasted three 10 hour shifts (30 hours); PowerBall® sub arc tip lasted sixteen 10 hour shifts (160 hours), lasting a total of 5.33 times longer.

## RESISTANCE TEST – LUG TO TIP

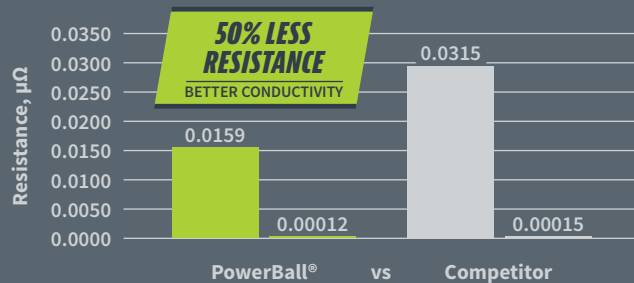

**1" Copper SAW Torch Extension**  
WTP-SAW-4



**2" Copper SAW Torch Extension**  
WTP-SAW-5



**5" Copper SAW Torch Extension**  
WTP-SAW-6

### POWERBALL® SUBMERGED ARC TORCHES

Part No.	Description
WTP-SAW-1-6K	SAW Torch Kit, 6" (152 mm) Length
WTP-SAW-1-11K	SAW Torch Kit, 11" (279 mm) Length
WTP-SAW-1-13K	SAW Torch Kit, 13" (330 mm) Length
WTP-SAW-1-14K	SAW Torch Kit, 14" (356 mm) Length
WTP-SAW-4	1" (25.4 mm) Copper SAW Torch Extension
WTP-SAW-5	2" (50.8 mm) Copper SAW Torch Extension
WTP-SAW-6	5" (127 mm) Copper SAW Torch Extension
WTP-SAW-9	SAW Flux Nozzle

Contact customer support if other lengths are required

### SUBMERGED ARC CONTACT TIPS

Part No.	Wire Size	Qty/Pack
WTP-3/32SA-PB-1	3/32" (2.4 mm)	5
WTP-1/8SA-PB-1	1/8" (3.1 mm)	5
WTP-5/32SA-PB-1	5/32" (4 mm)	5
WTP-3/16SA-PB-1	3/16" (4.8 mm)	5

# MECHANICAL TURN TABLES

## MECHANICAL TURN TABLE WWTT-2012

- ▶ 1,000 lb (453 kg) capacity accepts 20" – 26" (508 – 660 mm) drums
- ▶ Designed to dispense all sizes and varieties of wire for submerged arc (SAW) and GMAW welding applications
- ▶ Includes built-in fork slots and optional wheels for easy mobility
- ▶ 4-axis adjustable arm with ceramic inlet guide prevents wire shaving
- ▶ Quick disconnect allows for easy conduit connections
- ▶ Optional cover will not compromise accessibility

### SPECIFICATIONS

- ▶ Height: 42" (1.067 m)
- ▶ Width: 30" (762 mm)
- ▶ Length: 26" (660.4 mm)
- ▶ Weight: 142 lbs (64.5 kg)



## BRAKE KITS FOR MECHANICAL TURN TABLE

**WWTT-BRAKE-1-12 / WWTT-DB-13**

Slows and stops drum for welding applications where a higher wire feed speed is required and prevents over-rotating.

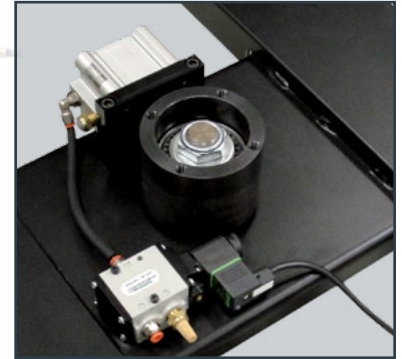

**Pneumatic Brake Kit**  
**WWTT-BRAKE-1-12**



Top view of turn table showing wire guide and wire retainer ring



**WWTT-WHEEL-12**  
Optional wheels



**WWTT-COVER-17**  
Optional cover for 26" (660 mm) drums (open and closed)

## WIRE PILOT® TURN TABLE ADAPTER KITS

**PFA-WWTT-B, PFA-WWTT-B1 and PFA-WWTT-B2**

- ▶ Firmly mounts the Wire Pilot® Feed Assist(s) (see page 11) and filter/regulator/lubricator to the top of the turn table
- ▶ Allows for longer conduit runs to the wire feeder
- ▶ Optional stabilizer recommended for PFA/Guide Module® mounts

Part No.	Description
WWTT-2012	Mechanical Turn Table for wire up to 5/32" (4 mm)
WWTT-BRK-12	Mechanical Turn Table (WWTT-2012) w/ assembled pneumatic brake
WWTT-WHEEL-12	Turn Table Optional Wheels (set of 4)
WWTT-BRAKE-1-12	Pneumatic Brake Kit for Mechanical Turn Table
WWTT-DB-13	Drag Brake Kit for Mechanical Turn Table
WWTT-WGM-BK	Guide Module® Support Bracket
WGM-4-BRKT	Wire Wizard Large Guide Module® Turn Table Adapter Bracket
WWTT-RL	Turn Table Replacement Liner, includes ceramic inlet
WWTT-23.4-DH-19	Turn Table Replacement Wire Retainer
WWTT-COVER-17	Turn Table Protective Cover for up to 26" (660 mm) drums
PFA-WWTT-B	Feed Assist Adapter Kit without Wire Pilot® Feed Assist
PFA-WWTT-B1	Feed Assist Adapter Kit with 1 Wire Pilot® Feed Assist
PFA-WWTT-B2	Feed Assist Adapter Kit with 2 Wire Pilot® Feed Assists
WWTT-WGM-SA	Large Guide Module® Support Arm Kit



**Guide Module® Support Bracket**  
**WWTT-WGM-BK**  
Mounting bracket for use with PFA-DD or PFA-LM

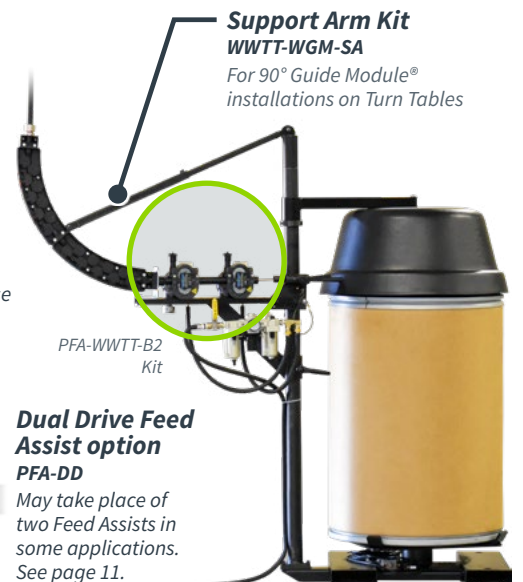

**Support Arm Kit**  
**WWTT-WGM-SA**  
For 90° Guide Module® installations on Turn Tables

**Dual Drive Feed Assist option**  
**PFA-DD**  
May take place of two Feed Assists in some applications. See page 11.

**Wire Pilot® Turn Table Adapter Kit with Dual Feed Assists and Large Wire Wizard® Guide Modules**  
Ideal setup for many SAW applications

# SAW WIRE DELIVERY SYSTEMS

## SINGLE & TANDEM VERTICAL DEREELERS FOR WOOD REELS

WWA-12-1 (single) and WWA-12-2 (tandem)

Wire Wizard® Single and Tandem Vertical Dereelers are built to deliver large diameter wire from 1/16" (1.6 mm) to 3/16" (4.8 mm) on up to 30" (762 mm) wood reels. Wire may be dispensed from either the top or the bottom of the dereeler. The tandem model (shown at right) offers dispensing of two wood reels with a small footprint, saving valuable floor space.

- ▶ Wire Wizard® Guide Modules (included) eliminate points of high friction when dispensing wire from the base
- ▶ Optional **Wire Pilot® Feed Assist(s)** recommended for reduced pull on the feed motor and long distance runs
- ▶ Adjustable brake allows fine tuning to prevent wire flip
- ▶ Polished ceramic inlet guides prevent wire shaving
- ▶ Capacity: 1,000 lbs (453 kg) per side

Part No.	Description
WWA-12-1	Single Vertical Dereeler for Wood Reels
WWA-12-2	Tandem Vertical Dereeler for Wood Reels



**WWA-12-2**  
Tandem Vertical Dereeler shown with optional Feed Assists and Large Guide Modules at top. Wire may also be dispensed from the base of the unit.

## SAW WIRE DELIVERY SYSTEMS FOR DRUMS & STEM PACKS

Wire Wizard® SAW Wire Delivery Systems for drums and stem packs are the ideal way to handle large diameter wire from 1/16" (1.6 mm) to 3/16" (4.8 mm) in bulk packaging. These setups allow for accurate welding with large wire by eliminating wire flip as well as preventing flux-core splitting, excessive tip wear, pulsating, burn backs and blown holes.

- ▶ **All systems designed to eliminate wire flip and excess friction**
- ▶ Drum systems compatible with up to 1,000 lb (453 kg) bulk drums and up to 3/16" (4.8 mm) wire
- ▶ Stem Pack systems compatible with 2,200 lb (998 kg) packages and up to 3/16" (4.8 mm) wire
- ▶ Does not change the cast of the wire
- ▶ Prevent tip wear, pulsating, burn back and blown holes
- ▶ Dispense large diameter wire at speeds up to 250 IPM
- ▶ **Wire Pilot® Feed Assist(s)** reduce pull on the feed motor and allow long distance wire feeding
- ▶ **Large Wire Guide Modules** (see page 8) may be installed at the wire source or near the feeder to eliminate excess friction
- ▶ Custom SAW wire delivery system solutions are available; contact customer service for details



Application with Turn Table and vertical wire feed



Application with Turn Table and horizontal wire feed



Motorized Stem Pack Dereeler; call for more info



Mezzanine Installation

# CONDUIT

## EXTRA FLEXIBLE CONDUIT

Our most durable conduit displays exceptional wear characteristics and a low friction coefficient. Perfect for manipulators, gantries, linear runs, or any application where a heavy duty, wear resistant conduit is required. Available in pre-cut lengths, 100 ft (30.5 m) bulk coils, or by the foot. Features a low friction smooth-feed wire coating and patented elliptical wire spring liners.

- ▶ **Available in two sizes for large wire:**  
FC-XH — For wire up to 3/32" (2.4 mm); FC-XH-LW — for wire 1/8" – 3/16" (3.2 – 4.8 mm)
- ▶ Available in cut lengths with attached bayonets on each end
- ▶ Available in 1 – 100 ft (305 mm – 30.5 m) continuous length coil
- ▶ Compression or swaged style connectors available (see page 6)

Part No.	Conduit Dimensions	Connector / Ferrule
FC-XH	0.291 ID (7.4 mm) x 0.610 OD (15.5 mm)	A-10R / A-10RFE
FC-XH-LW	0.390 ID (10 mm) x 0.750 OD (19 mm)	A-9/A-6HD / A-9-FE

### FC-XH PRE-CUT CONDUIT\*

with A-11XH Swaged Bayonet

Part No.	Description
FCXHS-120	120" – 10' (3 m)
FCXHS-180	180" – 15' (4.6 m)
FCXHS-240	240" – 20' (6.1 m)
FCXHS-300	300" – 25' (7.6 m)
FCXHS-600	600" – 50' (15.2 m)

### FC-XH-LW PRE-CUT CONDUIT\*

with A-11XH-LW Swaged Bayonet

Part No.	Description
FCXHS-LW-120	120" – 10' (3 m)
FCXHS-LW-180	180" – 15' (4.6 m)
FCXHS-LW-240	240" – 20' (6.1 m)
FCXHS-LW-300	300" – 25' (7.6 m)
FCXHS-LW-600	600" – 50' (15.2 m)

Add "ST" to end of part # for polymer strain relief, "SR" for steel strain relief (not available for FC-XH-LW).  
Delete "S" from part number for compression fittings.

Conduit  
FC-XH

Cutaway view



### Extra Flexible Conduit

Shown as cut length with connector options

**PATENTED ELLIPTICAL WIRE SMOOTH COATED SPRING LINERS!**

Compression

Swaged

### BULK CONDUIT\*

sold in 100' (30.5 m) sections

Part No.	Description
FC-XH-B	100' (30.5 m)
FC-XH-LW-B	100' (30.5 m)

\*Custom pre-cut lengths of conduit are available, contact customer service for ordering information.

### STRAIN RELIEF OPTIONS



**Steel Strain Relief option (-SR)**  
Available for FC-XH or EC-5 conduit only



**Polymer Strain Relief option (-ST)**  
Available for FC-XH conduit only

### CONNECTOR OPTIONS



Compression fitting with ferrule



Swaged fitting (flexible conduit only)



Self-threading (polymer conduit only)

## GREEN POLYMER CONDUIT

Known throughout the industry for its longevity and low friction coefficient, this durable conduit is manufactured with an advanced polymer formula for extended wear and durability. Recommended for stationary applications without bends or turns.

- ▶ Available in one size for large wire: EC-5 — For wire up to 3/32" (2.4 mm)
- ▶ Available in pre-cut lengths with attached self-threading bayonets or in bulk rolls
- ▶ Ideal for stationary applications without bends and turns
- ▶ Self threading or compression style connectors available (see page 6)

Part No.	Conduit Dimensions	Self Thread	Compression	Replace Ferrule
EC-5	0.400 ID (10.2 mm) x 0.600 OD	A-16F-5 or	A-10R	A-10RFE

### EC-5 PRE-CUT CONDUIT\*

A-16F-5 Bayonet Attached

Part No.	Description
EC5-120	120" – 10' (3 m)
EC5-180	180" – 15' (4.6 m)
EC5-240	240" – 20' (6.1 m)
EC5-300	300" – 25' (7.6 m)

Add "ST" to end of part # for polymer strain relief, "SR" for steel strain relief (not available for FC-XH-LW).  
Delete "S" from part number for compression fittings.

### Green Polymer Conduit

with connector options

**ADVANCED POLYMER FORMULA FOR EXTENDED WEAR AND DURABILITY!**

### BULK CONDUIT

In 50', 100', 250' or 500' rolls

Part No.	Description
EC-5-	50-B, 100-B, 250-B or 500-B

\* Custom pre-cut lengths of conduit are available, contact customer service for ordering information.

# CONNECTORS & ADAPTERS

## CONDUIT CONNECTORS

### POLYMER CONDUIT CONNECTORS



### EXTRA FLEXIBLE CONDUIT CONNECTORS



## POLYMER CONDUIT TOOLS



## POLYMER CONDUIT CONNECTORS

### EC-5 CONNECTORS

Part No.	Description
A-16F-5	Self Threading (3/8" NPT-F)
A-10R	Compression (Ferrule)
A-10RP*	Compression (1/4" NPT-F)
A-10R-SR	Strain Relief Connector
A-10R-QD	Connector with Disconnect
A-10R-QD-SR	Strain Relief with Disconnect

## EXTRA FLEXIBLE CONDUIT CONNECTORS

### FC-XH CONNECTORS

Part No.	Description
A-10R	Compression (Ferrule)
A-10RP*	Compression (1/4" NPT-F)
A-10R-SR	Strain Relief Connector
A-11XH	Swaged Connector
A-10R-QD	Connector with Disconnect
A-10R-QD-SR	Strain Relief with Disconnect

### FC-XH-LW CONNECTORS

Part No.	Description
A-6HD (or A-6)/A-9	Combination Compression
A-11XH-LW	Swaged Connector

NPT – National Pipe Threads  
M – Male | F – Female

\* For A-10RP use A-4 quick disconnect

### LARGE WIRE FITTINGS AND DISCONNECTS

0.375" (9.5 mm) I.D. for Large Wire over 3/32" (fittings require HD disconnects)

A-9      A-6HD      A-11XH-LW      A-5HD      A-4HD

1/2" NPS-M      3/8" NPT-M

## BULKHEAD CONNECTOR

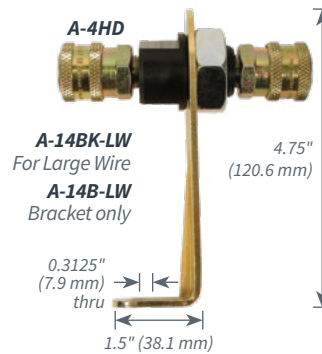

Ø 3/4" thru-hole

**Fixed Mount Direct Pull Kit**  
WWTT-DP & WWTT-DP-LW

Includes Ceramic Inlet Guide. Use WWTT-DP-LW for larger wires over 5/64" (2mm).

### STANDARD FITTINGS AND DISCONNECTS

0.250" (6.35 mm) I.D. for wire 3/32" and smaller

A-9      A-6      A-11XH      A-4-ST      A-4-ST-I      A-5

1/4" NPT-M      (inc. insulator)      1/2" NPS-M

## LINCOLN ELECTRIC® OUTLET ADAPTER

► For 10S wire feeder

WS-10S

Outlet Adapter for Lincoln 10S Feeder (Inlet Adapter WS-LW), including ceramic inlet



## LINCOLN ELECTRIC® TWIN ARC FEEDER INLET

End View

► For 10S, NA-3 NA-4 or NA-5 wire feeders

A-2NA-5





# CONDUIT BALANCERS & HANGERS

## RETRACTABLE CONDUIT/CABLE BALANCERS & HANGERS

- ▶ Balancer provides easy method of hanging conduit and cables
- ▶ Conduit Hanger prevents excess droopage
- ▶ Prevents cables from hanging in areas prone to damage
- ▶ Hangers feature velcro straps to secure cables and conduit

Part No.	Description
RCH-H	Conduit Balancer — Load: 2 – 4½ lbs (1 – 2 kg)
RCH-5-13	Conduit Balancer — Load: 5 – 13 lbs (2.3 – 6 kg)
RCH-11-19	Conduit Balancer — Load: 11 – 19 lbs (5 – 8.6 kg)
RCH-3-7-SH	Conduit Balancer with Shock Stop — Load: 3 – 7 lbs (1.4 – 3.2 kg)
RCH-22-27-SH	Conduit Balancer with Shock Stop — Load: 22 – 27 lbs (10 – 12.2 kg)
RCH-SH	Shock Stop Kit (only compatible with -SH models)
CHH-10	10" (254 mm) Conduit Hanger with two Retaining Straps
CHH-22	22" (559 mm) Conduit Hanger with four Retaining Straps



**Heavy Duty Balancers with Shock Stop -SH**

Prevents cable damage often caused by over-tensioning

**Balancers**  
Several models available, light duty (left) and heavy duty (right)

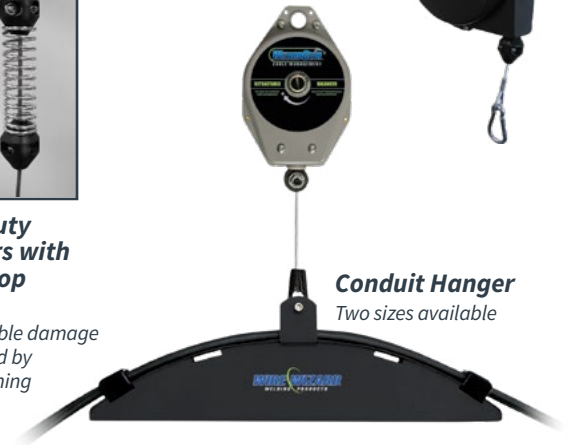

**Conduit Hanger**  
Two sizes available

# WIRE STRAIGHTENERS

Wire Wizard® offers two models of wire straighteners for straightening or recasting large wire. The main body is constructed of aluminum, making our straighteners some of the lightest in the market. All models are equipped with a locating calibration and a fine adjustment scale on the tension knob for easy and accurate adjustment.

## MEDIUM WIRE STRAIGHTENER WSM-100

For wire sizes 0.062 – 3/32" (1.6 – 2.4 mm)

- ▶ Dimensions: 5.71" W x 3.34" H x 1.875" D (145 mm W x 84.7 mm H x 47.63 mm D)
- ▶ Weight: 1.75 lbs (0.8 kg)

### FITTINGS & COMPONENTS FOR WSM-100



## LARGE WIRE STRAIGHTENER WSL-100

For wire sizes 3/32" – 5/32" (2.4 – 4 mm); ideal for heavy duty SAW applications

- ▶ Dimensions: 8.66" W x 4.09" H x 2.25" D (220 mm W x 103.8 mm H x 57.2 mm D)
- ▶ Weight: 4 lbs (1.8 kg)

### FITTINGS & COMPONENTS FOR WSL-100



# GUIDE MODULES FOR LARGE WIRE

## THE NEW PATH OF LEAST RESISTANCE!

The innovative **Wire Wizard Guide Module® System** utilizes a series of rollers with bearings to allow the weld wire to “coast” around bends and corners in the conduit, eliminating the points of high friction that occur in these areas. By eliminating the friction on the wire, it eliminates large wire feeding problems, improves welding consistency and enables considerably longer conduit runs of 100 feet or more, allowing wire packages to be centrally located. Each 45° Guide Module® may be connected to additional modules to form turns of 90°, 135° or 180° within the wire dispensing system.

Patented design.

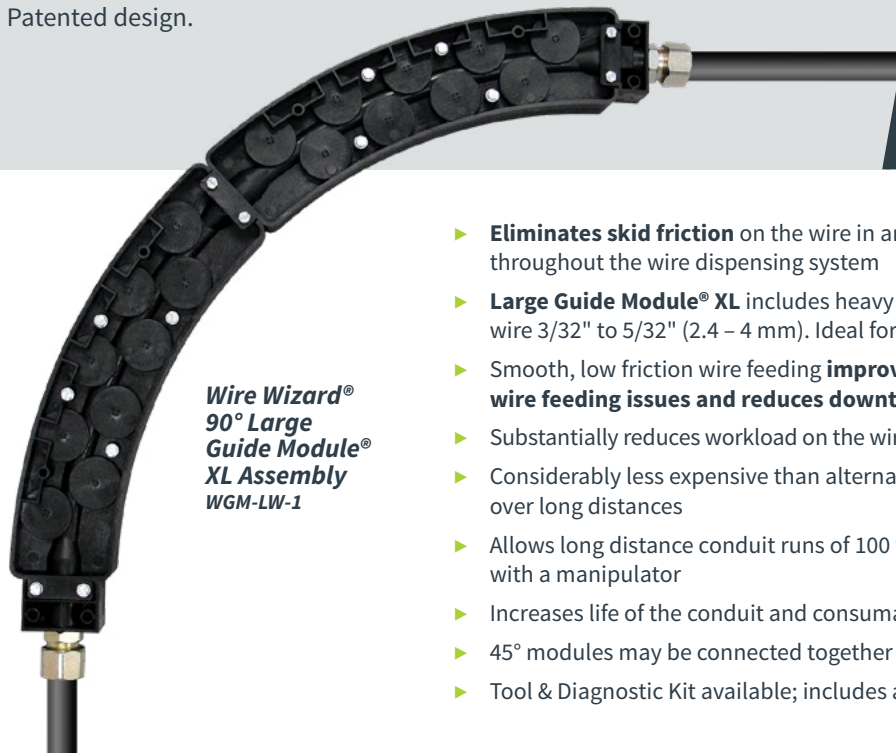

Wire Wizard®  
90° Large  
Guide Module®  
XL Assembly  
WGM-LW-1

- ▶ **Eliminates skid friction** on the wire in areas where bends/corners are necessary throughout the wire dispensing system
- ▶ **Large Guide Module® XL** includes heavy duty steel rollers with bearings, for large wire 3/32" to 5/32" (2.4 – 4 mm). Ideal for SAW welding applications!
- ▶ Smooth, low friction wire feeding **improves consistency of welds, eliminates large wire feeding issues and reduces downtime**
- ▶ Substantially reduces workload on the wire feed motor in applications using large wire
- ▶ Considerably less expensive than alternative methods of eliminating friction on wire over long distances
- ▶ Allows long distance conduit runs of 100 feet + (30.5 m +), perfect for applications with a manipulator
- ▶ Increases life of the conduit and consumables by reducing friction
- ▶ 45° modules may be connected together to form a 90° turn, 135° turn, 180° turn
- ▶ Tool & Diagnostic Kit available; includes assembly and testing tools

Installation with 90° Guide Modules on Turn Tables for SAW wire

## INTERNAL VIEW

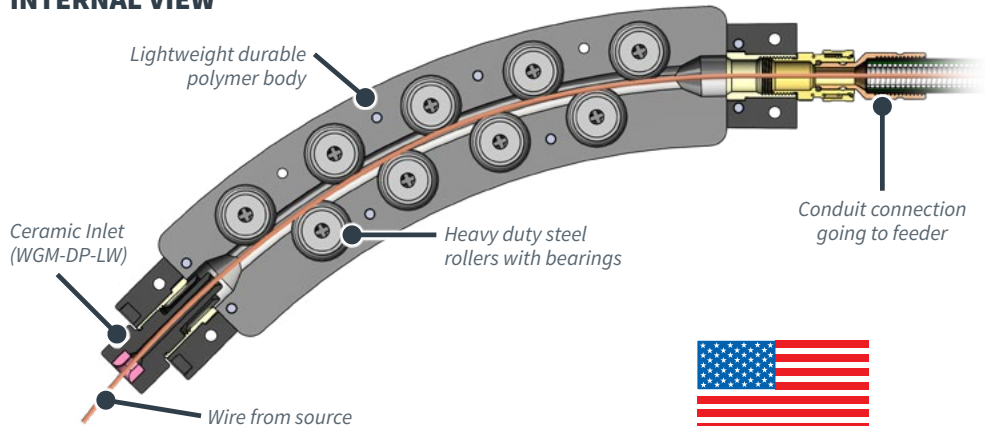

Large 90° Guide Modules® installed in a submerged arc welding application

## LARGE GUIDE MODULE® XL PARTS & ACCESSORIES

Part No.	Description
WGM-LW-1	Large Guide Module® XL, Single 45° (for wire 3/32" – 5/32" / 2.4 – 4 mm)
WGM-LW-ECK-50	Large Guide Module® End Cap Kit, 1/2" NPS-F (for A-9 connector)
A-5HD	Quick disconnect for WGM-LW-1 (requires HD conduit fittings)
A-9	Large Guide Module® Conduit Connector for FC-XH-LW Conduit
WGM-LW-049	Large Guide Module® Quick Disconnect Adapter (male end)
WGM-LW-BRKT	Hanging Bracket for Large Wire Guide Modules (45° or 90°)
PFA-54	Large Guide Module® Fixed Mounting Adapter for the Wire Pilot® Feed Assist
WGM-DP-LW	Guide Module® Direct Pull Inlet (includes ceramic inlet guide)
WGM-024	Guide Module® Support Bracket with Slotted Holes
WGM-A-10BK	Guide Module® Face Mount Bracket Kit with nut
WGM-2-BRKT	Guide Module® Insulated Face Mount Bracket Kit with nut and insulators
WGM-LBM-BRKT	Guide Module® L-bracket Mounting Kit
WGM-PFA-STAND	Adjustable Drum/Reel Stand for Guide Modules, 50" – 90" H (1,270 – 2,286 mm); includes one Arm Assembly
WGM-ATK	Guide Module® Tool & Diagnostic Kit – includes required tools for assembly and testing

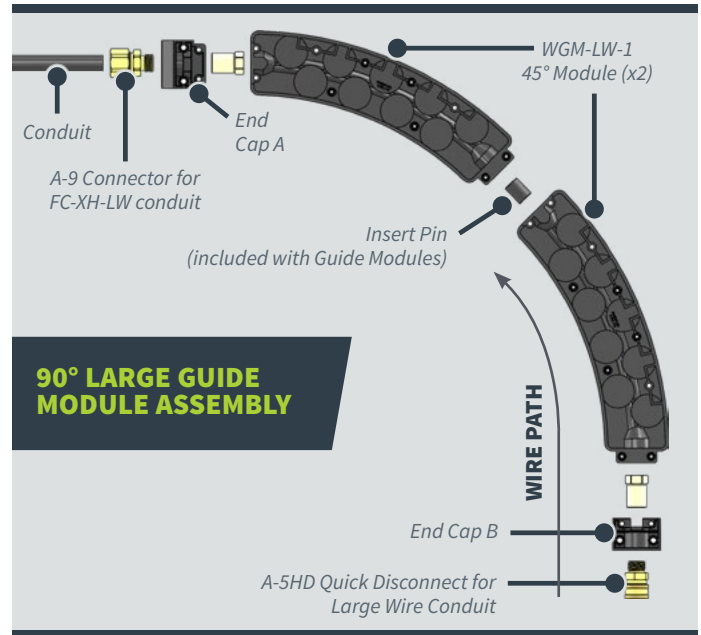

## COMPONENTS & MOUNTING ACCESSORIES

**END CAP CONNECTORS**

Each kit includes one A and one B end cap

**End Cap A**

**End Cap B**

**WGM-LW-ECK-50**  
For WGM-LW-1

**CONDUIT CONNECTOR OPTIONS**

**A-9**  
For connecting FC-XH-LW to WGM-LW-1

**A-5HD**  
Quick disconnect for WGM-LW-1

**90° HANGING BRACKET KIT**

**WGM-LW-BRKT**

**FACE MOUNT BRACKET KIT**

**ALLOWS 360° DIRECTIONAL ADJUSTMENT**

**WGM-A-10BK**  
Order WGM-2-BRKT for insulated connections

**TURN TABLE MODULE ADAPTER**

**SECURES MODULES TO WIRE WIZARD® TURN TABLE**

**WGM-4-BRKT**  
Compatible with WGM-1, WGM-1-S and WGM-LW-1

**L-BRACKET MOUNTING KIT**

**WGM-LBM-BRKT**

**DIRECT PULL INLET**

**WGM-DP-LW**  
Includes ceramic inlet to prevent wire shaving

**GUIDE MODULE® STAND**

**APPLICATION WITH MECHANICAL TURN TABLE**

**Mechanical Turn Table**  
Model WWTT-2012 with WWTT-COVER-17 cover

**Wire Pilot® Feed Assist option**  
Model PFA-DD Dual Drive Feed Assist shown

**FC-XH-LW Conduit and Connectors**

**WGM-4-BRKT**  
Bracket connecting 90° Large Guide Module Assembly

**Guide Module® Stand WGM-PFA-STAND**  
Includes stand and one adjustable extension arm

Adjustable height from 50" – 86" (1.3 – 2.2 m)  
Adjustable arm length from 4" – 19" (102 – 483 mm)

**SLOTTED SUPPORT BRACKET**

**WGM-024**

**MALE DISCONNECT FITTINGS**

**HD Disconnect**

**WGM-LW-049**  
Fitting for WGM-LW-1

**FEED ASSIST MOUNT**

**PFA-54**  
For direct mount to Wire Pilot® Feed Assist

# LARGE GUIDE MODULE FLEX

**ELIMINATES EXCESS FRICTION ON LARGE WIRE IN WELDING APPLICATIONS WITH LINEAR MOVEMENT!**



Featuring the same innovative concept as the fixed radius Wire Wizard® Guide Modules, the **Guide Module® FLEX System** is designed especially for welding applications using a traversing axis, gantry or boom. The FLEX utilizes a series of heavy duty rollers with bearings to eliminate skid friction on the wire, providing a smooth, consistent wire feed. Externally mountable to select igus® e-chain® cable carrier systems. **Large FLEX Modules** compatible with steel wire 1/16" to 5/32" (1.6 – 4 mm), making them an ideal solution for SAW applications. Patent pending design.



Internal view showing path of wire along rollers.



**Large Guide Module® Flex**  
10 ft section with End Caps

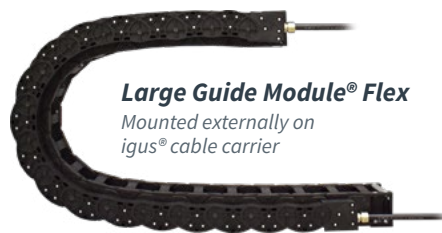

**Large Guide Module® Flex**  
Mounted externally on igus® cable carrier



End cap without mounting flange



End cap with mounting flange

## LARGE GUIDE MODULE® FLEX LINK & END CAP DIMENSIONS

Use dimensions noted to determine length required for your application

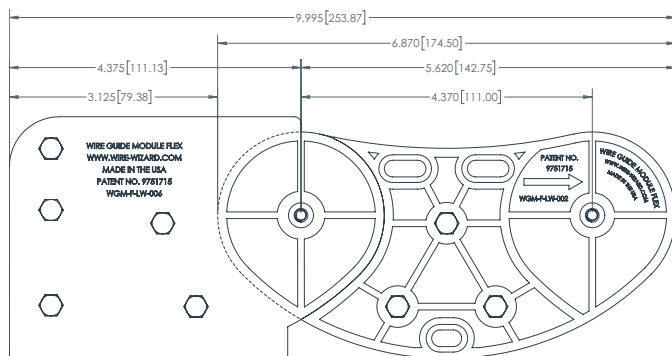

## LARGE GUIDE MODULE® FLEX BEND RADIUS DIMENSIONS

Use dimensions noted to determine length required for your application

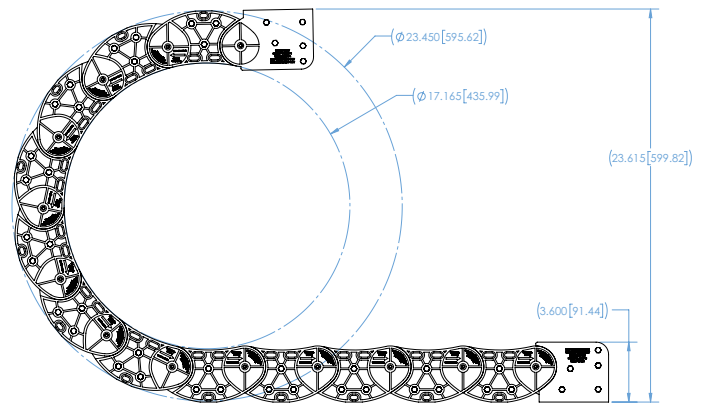

## LARGE GUIDE MODULE® FLEX PARTS & ACCESSORIES

Part No.	Description
WGM-F-LW-5	Large Guide Module® FLEX 5 ft (1.5 m) Section — requires end caps
WGM-F-LW-10	Large Guide Module® FLEX 10 ft (3 m) Section — requires end caps
WGM-F-LW-IL	Large Guide Module® FLEX Individual Module (for custom lengths, approx. 2 = 1 ft)
WGM-F-LW-ECK-F	Large Guide Module® FLEX End Cap Kit — includes both End Caps, with mounting flange
WGM-F-LW-ECK	Large Guide Module® FLEX End Cap Kit — includes both End Caps, no mounting flange
WGM-F-LW-DF	Drilling Fixture for externally mounting Large Guide Module FLEX to select igus® cable carriers

Additional lengths, sizes and components may be available, contact customer service or see website for details

### Drilling Fixture for Large Guide Module® FLEX WGM-F-LW-DF

For externally mounting large Guide Module® FLEX to select igus® cable carriers

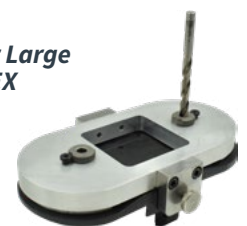

# WIRE PILOT FEED ASSISTS

The **Wire Pilot® Pneumatic Feed Assist** provides an economical way to help the wire feeder move wire through the conduit in applications where there must be minimal friction, travel a long distance or where the workload on the wire feeder must be reduced. When combined with Guide Modules, it allows the ultimate flexibility when it comes to wire delivery and **wire packages can be located 150 ft (46 m) or more away from the arc.** Using only compressed air, the Feed Assist easily relieves pounds of pulling force from the feed motor. Adjustable torque setting allows fine tuning for different wire sizes and distances. Patented design.

- ▶ **Eliminates drag coefficient inside the conduit**, solving many wire delivery issues with large diameter wire
- ▶ Provides “Push-Pull” system to get wire from source to the feeder
- ▶ Extends conduit life and increases arc-on time
- ▶ **Allows the use of bulk wire** (when used with mechanical turn table or dereeler) in large wire applications that would normally require spools, reducing wire cost and cutting downtime for wire changeover
- ▶ Enables longer conduit runs (150 ft/46 m+), ideal for SAW applications with large manipulators
- ▶ Prevents arc failures caused by wire feeding problems
- ▶ PFA-LM model is adaptable to the Mechanical Turn Table for bulk wire delivery
- ▶ Available with or without industrial enclosure

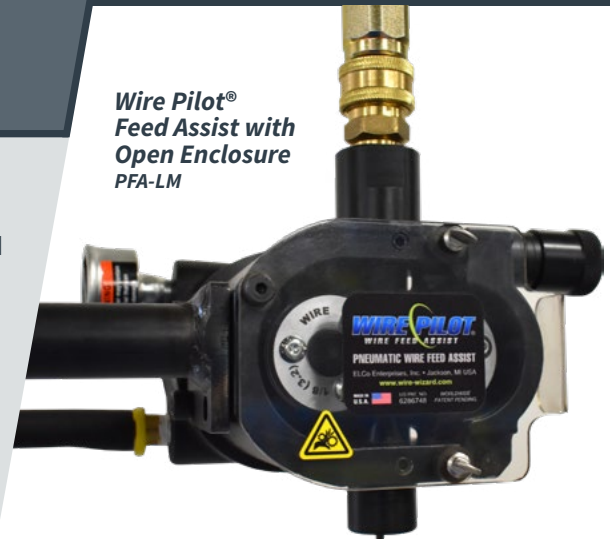

Tandem PFA-LM Wire Feed Assists installed on a Turn Table for Large Wire Dispensing

## RECOMMENDED FEED ASSIST MODELS BY WIRE SIZE & LENGTH OF WIRE DELIVERY RUN

Length	0 - 25 ft	0 - 25 ft	0 - 25 ft	0 - 25 ft
Up to 1/16" (1.6 mm) wire	PFA-LM	PFA-LM	PFA-LM	PFA-LM or PFA-DD (with multiple turns for >150 ft)
1/16 - 3/16" (1.6 - 4.8 mm) wire	PFA-DD	PFA-DD	PFA-LM x 2	PFA-LM x 2

## DUAL DRIVE WIRE FEED ASSIST PFA-DD

The new Dual Drive Wire Pilot® Feed Assist is designed to handle large wire up to 3/16" (4.8 mm) and extra-long distance applications using standard size MIG wires. This heavy duty model features four drive rolls (sold separately) and additional torque to provide more power to effortlessly deliver wire to the feeder.

- ▶ Ideal solution for submerged arc welding applications using 1/16" (1.6 mm) and larger wire
- ▶ Utilizes same mounting pattern as the PFA-LM Feed Assist and may be mounted to the same adjustable stands and brackets
- ▶ Compatible with standard Wire Feed Assist drive rolls
- ▶ May be installed on the Wire Wizard® Mechanical Turn Table

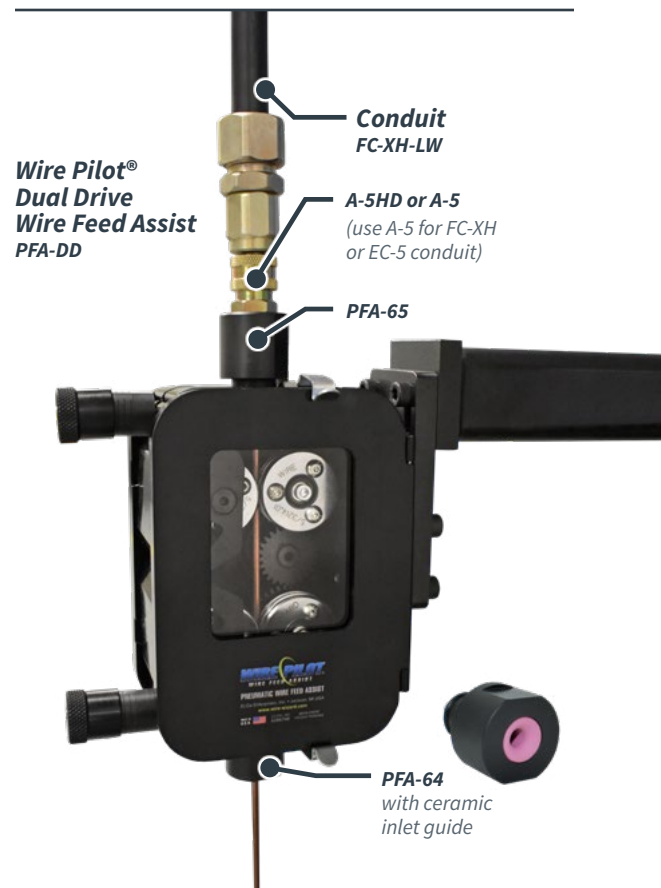

# WIRE FEED ASSIST OPTIONS & ACCESSORIES



## PFA Drive Rolls

Various size options

All PFA drive rolls are **hard chromed and polished** for maximum performance and durability. Sold individually.

### PFA-64

Large Wire Inlet Guide with Ceramic Inlet for PFA-LM or PFA-DD



## Guide Module Mounting Adapter

PFA-54

Mounts Large Wire Guide Modules to the PFA-LM



## Extension Arm

PFA-WM-EA

Fits any Feed Assist Model



## Feed Assist Dual Mount Bracket

PFA-DM

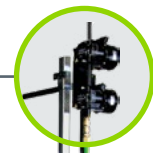

## Adjustable Stand for Feed Assists and Guide Modules

WGM-PFA-STAND

Adjusts to 86" (2.2 m); includes 1 arm (additional arms sold separately)



## Optional Wire Spool Holder for Stand

WGM-PFA-STAND-SPOOL

Holds spools up to 4" (102 mm) wide



Wire Pilot® Feed Assists in use with a Vertical Dereeler



Wire Pilot® Feed Assists in use with a Mechanical Turn Table

## WIRE PILOT® FEED ASSIST & ACCESSORIES

Part No.	Description
PFA-LM	Wire Pilot® Feed Assist with open enclosure, includes PFA-FRL Filter/Regulator/Lubricator
PFA-DD	Wire Pilot® Dual Drive Feed Assist for Large Wires, includes PFA-FRL Filter/Regulator/Lubricator
A-5	Inlet/Outlet Quick Disconnect (insulator U-005 sold separately) for PFA-LM
A-1B-C	Steel Inlet Guide with Quick Disconnect for PFA-LM
PFA-35-15	Inlet Guide with Ceramic Inlet for PFA-LM
PFA-64	Large Wire Inlet Guide with Ceramic Inlet for PFA-LM or PFA-DD
PFA-65	Inlet/Outlet Guide for PFA-LM or PFA-DD, 1/2" NPS-F; two included with each Feed Assist
PFA-34	Inlet Guide with 3/8"-18 NPS-F threads (connects to A-4HD disconnect) for PFA-LM
PFA-35	Inlet Guide with Ceramic Inlet for PFA-LM
PFA-54	Mounting adapter for Large Wire Guide Modules
PFA-WWTT	Turn Table Adapter Kit for Wire Pilot® Feed Assist
WGM-PFA-STAND	Adjustable Wire Pilot® Feed Assist Stand for Drums or Spools
WGM-PFA-STAND-ARM	Additional Arm for Wire Pilot® Feed Assist Stand
WGM-PFA-STAND-SPOOL	Wire Spool Holder for Wire Pilot® Feed Assist Stand
PFA-SK	24-volt Pneumatic Solenoid with Cable
PFA-RK	Wire Retract Kit for Reversing Wire Feed (24 V)
PFA-DM	Wire Pilot® Dual Mount Bracket
PFA-WM-EA	Wire Pilot® Extension Arm Bracket

## WIRE PILOT® DRIVE ROLLS FOR LARGE WIRE

Part No.	Description
PFA-DR-1-16	Feed Assist Drive Roll for 1/16" (1.6 mm) wire
PFA-DR-5-64	Feed Assist Drive Roll for 5/64" (2.0 mm) wire
PFA-DR-3-32	Feed Assist Drive Roll for 3/32" (2.4 mm) wire
PFA-DR-1-8	Feed Assist Drive Roll for 1/8" (3.2 mm) wire
PFA-DR-5/32	Feed Assist Drive Roll for 5/32" (4.0 mm) wire
PFA-DR-3/16	Feed Assist Drive Roll for 3/16" (4.8 mm) wire

# DRUM AND REEL HANDLING EQUIPMENT

## DRUM LIFTER *FDL*

- ▶ Spring loaded clamp design holds drum firmly in place
- ▶ For fiber or steel drums (chimed only)
- ▶ Accepts diameters from 18.5" – 26" (470 mm – 660.4 mm)
- ▶ 1,200 lb (544 kg) capacity



Note: Drum rim must be within 1" (25.4 mm) of the top of the drum. Not for lifting over 10" (254 mm) high.

Shown with *FDL-FA*

## FORK LIFT ADAPTER *FDL-FA*

- ▶ Adjustable T-handle keeps adapter from sliding off fork
- ▶ Safety style clasp secures adapter to drum lifter
- ▶ 1,200 lb (544 kg) capacity



## ISO DRUM LIFTER (ADJUSTABLE) *FDL-HS*

- ▶ Easily attaches to chimeless ISO drums with straps or handles
- ▶ Accepts 20" – 26" (508 to 660 mm) drum diameters, including
- ▶ 1,200 lb (544 kg) capacity

## 21" DRUM LIFTER (NON-ADJUSTABLE) *FDL-21*

- ▶ Accepts 20" – 21" (508 – 533 mm) drum diameters
- ▶ 1,200 lb (544 kg) capacity

## 24" DRUM LIFTER (NON-ADJUSTABLE) *FDL-24*

- ▶ Accepts 23" – 24" (584 – 610 mm) drum diameters
- ▶ 1,200 lb (544 kg) capacity



## HEAVY DUTY WOOD REEL DOLLY *WRD-18*

- ▶ Specifically designed to transport wood reels
- ▶ All steel construction built for rugged industrial use
- ▶ Convenient, reversible and removable handle
- ▶ Locking 6" swivel wheels standard

### SPECIFICATIONS

- ▶ Deck Height: 9.24" (235 mm)
- ▶ Dimensions: 41.36" (1,051 mm) H x 39.5" (1,003 mm) L x 24.375" (619 mm) W
- ▶ Capacity: 1,400 lbs (635.6 kg)
- ▶ Weight: 65 lbs (29.5 kg)

## **SOLVING WELDING CHALLENGES & MANUFACTURING INNOVATIVE WELDING PRODUCTS SINCE 1985**

**Wire Wizard® Welding Products** is recognized as the industry leader in weld wire delivery products, high performance torch products, weld cell support equipment and weld cell optimization. Since we began in 1985, we've prided ourselves on both quality and innovation. Our product lines include Wire Wizard® Wire Delivery Equipment, Blue Magic® Anti-spatter, PowerBall® Torch Products, Torch Wizard® Nozzle Cleaning Stations and WizardGear® Robot Cable Management Systems. Wire Wizard® has solutions for virtually every arc welding application, including robotic, fixed automation, semi-automatic and submerged arc welding.



ELCo Enterprises headquarters in Jackson, Michigan

### **ELCO ENTERPRISES, INC.**

5750 Marathon Drive  
Jackson, Michigan 49201 USA

**Phone** 517.782.8040

**Fax** 517.782.8039

**Toll-Free** 866.584.7281



**WIRE WIZARD® WIRE DELIVERY EQUIPMENT**  
**POWERBALL® & E-POWER® TORCH PRODUCTS**  
**LOW FRICTION CONDUIT & CONNECTORS**  
**WIRE WIZARD® GUIDE MODULE® SYSTEM**  
**WIZARDGEAR™ CABLE MANAGEMENT**  
**BLUE MAGIC® & BLUE CHILL® ANTI-SPATTER**  
**TORCH WIZARD® CLEANING STATIONS**  
**WELD CENTRAL® OPTIMIZATION SYSTEM**  
**DRUM & REEL HANDLING EQUIPMENT**



**SUSTAINING MEMBER**



**ISO 9001:2015  
CERTIFIED**